

# DEVELOPMENT OF OIL-AIR MIST LUBRICATION SYSTEM IN ULTRA HIGH SPEED GRINDING SPINDLE

K.Ramesh<sup>1</sup>, S.H.Yeo<sup>2</sup>, Z.W.Zhong<sup>2</sup> and Akinori Yui<sup>3</sup>

<sup>1</sup> *Gintic Institute of Manufacturing Technology, Singapore*

<sup>2</sup> *Nanyang Technological University, Singapore*

<sup>3</sup> *Okamoto Machine Tool Works, Annaka, Japan*

## Abstract

*The combination of ultra high grinding wheel speed and super abrasive evolve high efficiency grinding concept. But, the high investment decelerates the rate of spread. The spindle unit covers nearly 60% of the total outlay, due to elaborate oil management for cooling and lubrication. This paper discusses the effectiveness of oil-air mist system when applied to the high speed rolling elements. An ultra high grinding wheel spindle unit was built with this system and experimented. Total heat generation due to friction and gyro induced torque was evaluated. Study was performed to establish the heat transfer components.*

## Nomenclature

$g$	: Acceleration due to gravity
$T_b$	: Ball temperature in °C
$\alpha$	: Contact angle in radians
$Q_c$	: Convective heat transfer
$H$	: Convective heat transfer co-efficient
$\gamma$	: Density of Si <sub>3</sub> N <sub>4</sub> ball kg/m <sup>3</sup>
$d_b$	: Diameter of the ball in m
$f$	: Friction co-efficient Si <sub>3</sub> N <sub>4</sub> ball & steel races
$M_s$	: Twisting moment that cause slip
$M_{ds}$	: Frictional torque due to sliding kg-m
$M_{gr}$	: Gyro torque for ball spin -kg.m
$H_f$	: Heat developed at the ball race contact
$Q_l$	: Latent heat dissipation
$T_m$	: Mist Temperature in °C
$Z$	: No of balls
$D_o$	: Pitch circle diameter of bearing in m
$P$	: Radial force in N
$r_o$	: Radii of outer race way in m

$r_i$	: Radii of inner race way in m
$Q_s$	: Sensible heat -colliding of mist
$Q_{s-o}$	: Sensible heat -colliding of oil
$Q_{s-a}$	: Sensible heat -colliding of air
$C_a$	: Specific heat of air
$C_o$	: Specific heat of oil
$\omega_b$	: Spin speed of ball in rad / sec

## 1. Introduction

Application of super abrasives in ultra-high speed grinding technology paved the way for high specific material removal rate. Fragmentation of chip segment enables deployment of higher feed rate. However, the usage is fairly little due to the heavy capital outlay. Ultra-high speed spindle, which is a key component, covers nearly 60% of the total machine cost due to elaborate oil management in spindle design for cooling and lubrication [1,2,3]. The pressurized cooling oil in the high speed spindle demands cumbersome sealing arrangement. Heat generation, due to churning of oil and frictional hydraulic power loss reduces the efficiency of jet oil lubrication. Therefore, an alternative lubrication and cooling method that simplifies the spindle construction with effective heat removal becomes essential.

## 2. Review of past development

An high speed spindle with piezoelectric nozzles for oil-air lubrication was developed and reported. In this method the fluctuation of oil-air supply was suppressed [4]. Holes were drilled into the outer race of the spindle bearing system and oil-mist was supplied to overcome the air turbulence around the rotating cage. The lubrication film thickness at different spindle speed are measured and reported [1]. A draft plan to develop an high speed grinding machine of

*Correspondence and offprint requests to:* K. Ramesh, Research Fellow, Gintic Institute of Manufacturing Technology, 71 Nanyang Drive, Nanyang Technological University, Singapore 638 075  
E-mail: [rkuppuswamy@gintic.gov.sg](mailto:rkuppuswamy@gintic.gov.sg)

250m/s outlined the advantage of oil-air lubrication method [2]. The effective lubrication was a key issue to enhance the performance of Si<sub>3</sub>N<sub>4</sub> angular contact ball bearings[5].

The increase in spindle speed has also increased the heat generation of spindle bearings system[6]. Liquid droplet study confirmed the effectiveness of convective heat transfer in cooling [7]. High performance cooling can be achieved in mist cooled heat exchanger [8]. An United states patent reported the spindle device having bearings lubricated with oil jet[3]. Composite bearing system was adopted for the construction of ultra high speed grinding spindle (UHSG) unit and established the increase in natural frequency, damping ratio and decreased heat generation [9]. In UHSG spindle contact stress fatigue was considered as the primary mechanism for the wear of silicon nitride balls [10]. The performance of the previously built UHSG spindle unit is given in Table 1.

Table 1 Summary of ultra high speed spindle development

Lubrication method	Wheel speed in m/s	DN x 10 <sup>6</sup>	kW/rpm x 10 <sup>-4</sup>	Ref..
Grease	125	0.71	13.7	[13]
Hydrodynamic	160	0.43	15	[13]
Grease	-	1.0	5.8	[ 1 ]
Magnetic	150	0.5	22	[13]
Oil jet	340	1.05	8.3	[13]
Grease	185	0.54	55.5	[13]

### 3. Development of UHSG spindle

Usually high speed relates to smaller bearings and low power motors but high rigidity implies to higher bearings. In the developed spindle unit size of bearing, rolling element, pre-load, motor and oil-air lubrication cum cooling system are considered to achieve high speed together with high power.

Fig. 1 describes the longitudinal assembly of the developed spindle unit. The main spindle shaft is suspended with Si<sub>3</sub>N<sub>4</sub> ceramic ball bearings in the front and rear portion. The front and rear unit of the spindle is suspended with back to back bearing mounting to ensure higher rigidity. The oil - air system shown in Fig. 4 supply the oil-air mist to the ceramic ball bearings.

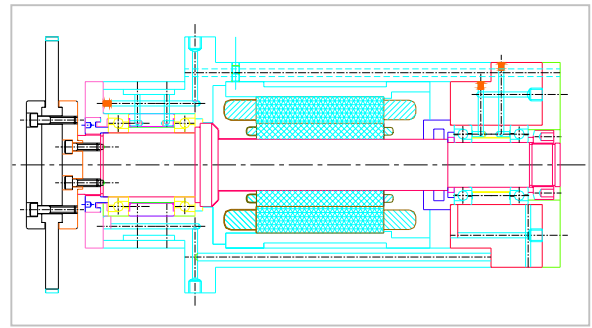

Fig. 1 Ultra high speed grinding spindle -longitudinal assembly

The specially designed mixing valve performs lubrication and cooling through intermittent feeding of 0.03cc of turbo-oil at every 8minutes into a stream of compressed air. A small chamber in the spindle housing collects the condensed air.

Table 2 Specification of the developed UHSG Unit

Capacity	i. Power in kW	10
	ii. Max. wheel speed in m/s	210
	iii. Maximum wheel size diameter x width - mm	200 x 20
Construction	i. Bearing rolling elements	Si <sub>3</sub> N <sub>4</sub>
	ii. Bearing arrangement	Back to back & light pre-load
	iii. Lubrication	Oil-air mist type
	iv. Oil-air quantity	0.08cc / 8min
	v. Condensed air collection	Yes
	vi. Heat shield	both ends
Rigidity	i. Radial stiffness at wheel plane in N/μm	84 to 101
	ii. Axial stiffness in N/μm	84 to 87

An integral, continuous duty, AC squirrel cage motor elements of 10kW capacity forms part of the unit. Around the power zone wider area coolant jacket is built in to speed up the heat dissipation. Frequency drive controls the AC squirrel cage motor.

A precise locating diametrical recess in the spindle nose eases the wheel changing. Cartridge design was followed and safety against the thermal seizure was included. Table 2 gives the specifications of the developed spindle unit and Fig. 2 shows the photo of the developed spindle unit.

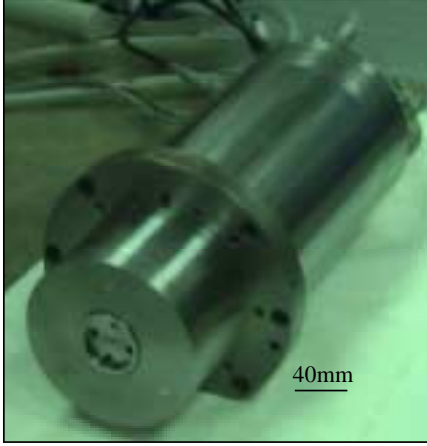

Fig.2 -Photo of the developed spindle unit

#### 4. Hypothesis

The effectiveness of heat transfer in oil-air lubrication system can be explained with the following analogy using Fig.3.

Let us consider a rolling element of diameter “d” rotates at velocity V in a pitch diameter “D”. The rolling element spins with its own axis at a velocity “v”. The oil –air mist is applied from a nozzle having diameter “a” from a distance “l” from the rolling element.

The major portion of heat source in the rolling element are mainly due to frictional torque and gyro torque at the rolling element [12].

The total heat developed at the ball race contact can be given as,

$$H_f = \omega_b M_s \quad \dots\dots\dots 1$$

The twisting moment that create slips in rolling bearings is the vectorial addition of friction and gyro induced moment and define as given below,

$$M_s = (M_{ds} + M_{gr})K \quad \dots\dots\dots 2$$

where, k- proportional constant.

The frictional torque due to sliding is given in the following equation [12].

$$M_{ds} = \frac{PD_o Z}{4d_b} \left[ 1 - \frac{d_b^2}{D_o^2} \cos^2 \alpha \right] [r_o B_o - r_i B_i] f \quad \dots\dots\dots 3$$

B<sub>o</sub> & B<sub>i</sub> –factors based on geometric condition of raceway surfaces =1.

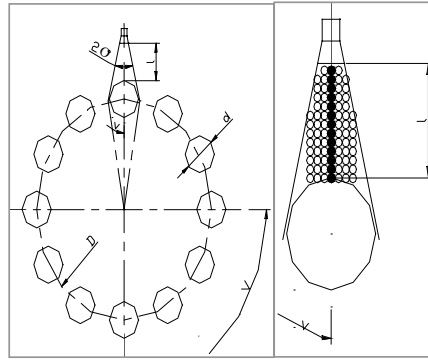

Fig.3 Mist lubrication of rolling element

The gyroscopic torque – M<sub>gr</sub> is given in the following equation [12].

$$M_{gr} = \frac{\pi}{60} d_b^2 \frac{\gamma}{g} \omega_b Z \sin \alpha \quad \dots\dots\dots 4$$

For precision built spindle unit k=1 and the equation 2 is rewritten after substituting 3 &4,

$$M = \frac{PD_o Z}{4d_b} \left[ 1 - \frac{d_b^2}{D_o^2} \cos^2 \alpha \right] [r_o - r_i] f + \frac{\pi}{60} d_b^2 \frac{\gamma}{g} \omega_b Z \sin \alpha \quad \dots\dots\dots 5$$

Where,

$$r_o = \frac{D_o}{2} + \frac{d_b}{2} \quad \dots\dots\dots 6 \quad r_i = \frac{D_i}{2} - \frac{d_b}{2} \quad \dots\dots\dots 7$$

Substituting the ball diameter and pitch circle of rolling diameter, the total twisting moment i.e., equation 5, that causes slip can be rewritten as,

$$M = \frac{PD_o}{4d_b} \left[ 1 - \frac{d_b^2}{D_o^2} \cos^2 \alpha \right] d_b f + \frac{\pi}{60} d_b^2 \frac{\gamma}{g} \omega_b \sin \alpha \quad \dots\dots\dots 8$$

The following data are applied to the built spindle unit; Inner diameter-50mm; No of balls –15; Outer diameter-80mm; Ball diameter-10mm; width-16mm; Pitch circle of rolling element –65mm; Contact angle-15°

Substituting these values the equation 8 is redefined as follows,

$$M = 0.0016 f .P + 0.00044 \omega_b \quad \dots\dots\dots 9$$

Therefore, the total heat developed is recomputed as follows,

$$H_f = \omega_b (0.0016 f .P + 0.00044 \omega_b) \quad \dots\dots\dots 10$$

From this derived equation it was confirmed that the heat developed is a second order equation of rolling element speed. Such heat energy is driven away by employing the oil-air mist lubrication system.

At any rolling element the following are the heat equilibrium situation can be applied,

Heat formed = Heat transferred + Internal energy rise

In the mist cooling the heat transferred consists of three components [ 8], They are,

i. Convective heat transfer,  $Q_c$

$$Q_c = h.A.(T_b - T_m) \text{ —————11}$$

where, h- Convection co-efficient –3000-200,000 W/m<sup>2</sup> °C[16],  $T_b$  - ball temperature,

$T_m$  - Mist temperature &

A = Surface area of ball = 0.0003m<sup>2</sup>

Substituting the above values equation 11 can be re-written as,

$$Q_c = 0.0003.A.(T_b - T_m) \text{ ————— 12}$$

ii. Dissipation of latent heat due to evaporation -  $Q_l$

$$Q_l = M_m L_h \text{ ————— 13}$$

Where,  $M_m$  - Mass balance of evaporating liquid- 3.8x10<sup>-8</sup>m<sup>3</sup>/s ; L-Latent heat of evaporation for water vapor- 333.4 KJ/Kg

Substituting the above values, the  $Q_l$  value for our application stands at 12.6692 J/s

ii. Sensible heat due to colliding and leaving droplet -  $Q_s$

This have two components, they are,

◆ Sensible heat due to colliding of oil particles,  $Q_{s-o}$

◆ Sensible heat due to colliding of air particles,  $Q_{s-a}$

The total sensible heat is the summation of these components and given as follows;

$$Q_s = Q_{s-o} + Q_{s-a} \text{ ————— 14}$$

The sensible due to colliding of oil particles is given below;

$$Q_{s-o} = M_o C_o (T_b - T_o) \text{ —————15}$$

$M_o$ - Mass flow rate of oil in kg/s;  $C_o$  - Sp. heat capacity of oil -J/kg.K ;  $T_b$  - Ball Temperature in °C &  $T_o$  - Supply Oil temperature °C

The sensible heat due to colliding of air particles is given as;

$$Q_{s-a} = M_a .C_a (T_b - T_a) \text{ —————16}$$

Where,  $M_o$ - Mass flow rate of air in kg/s;  $C_o$  - Sp. heat capacity of air-J/kg.K ;  $T_b$  - Ball Temperature in °C &  $T_o$  - Incoming air temperature °C

The following data are employed in the oil mist system, Sp. heat of air-1005.669 J/ Kg. °K; Oil flow rate -3x 10<sup>-9</sup> m<sup>3</sup>/ sec; Sp. heat of turbine oil 1762.224 J/ Kg. K; Mass flow rate of air-3.5 x 10<sup>-8</sup> Kg/s; Mass flow rate of oil - 2.5 x 10<sup>-6</sup>kg /s; Density of air - 1.176 Kg/m<sup>3</sup>; Density of oil - 826Kg/m<sup>3</sup>; Flow rate of air -3x 10<sup>-8</sup> m<sup>3</sup>/ sec

Substituting these values to equation 15 & 16 and simplified as below;

$$Q_{s-o} = 0.00441(T_b - T_o) \text{ —————17}$$

$$Q_{s-a} = 0.0000352(T_b - T_a) \text{ ————— 18}$$

The total transferred is the summation of equation 12, 13, 17 & 18 and given equation 19 ;

$$Q = 12.67 + 0.0003h(T_b - T_m) + 0.00003(T_b - T_a) + 0.00441(T_b - T_o) \text{ —19}$$

Assuming the oil, air and mist temperatures are equal, equation 19 can be simplified to,

$$Q = 12.67 + (T_b - T_m)[0.0003h + 0.004445] \text{ —20}$$

From the above inference it is clear that the heat transfer is primarily depends upon two factors which are convection co-efficient and temperature difference of the mist and the rolling element.

## 5. Experimentation

Fig. 4 shows the experimental set up. Thermocouple is used to measure the temperature at the nearest outer race of the bearing. Spindle power is recorded using a built in ammeter. Capacity type sensor was used for displacement measurement. Vibration was checked using the balance monitor SB-7001.

The lubrication film size was measured using capacitive method. Outer and inner races are considered as the plates of the condenser and oil film as the condenser. The change in film thickness affects the condenser capacity, which is measured and converted to unit of microvolts.

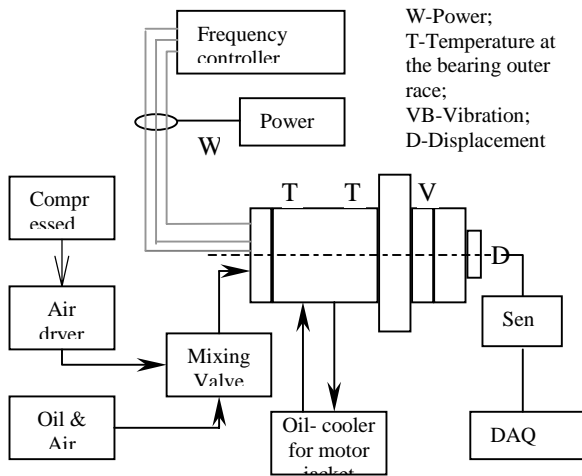

Fig. 4 Experimental set up for the ultra high-speed spindle unit

## 6. Results and discussion

### 6.1 Temperature and lubrication film thickness

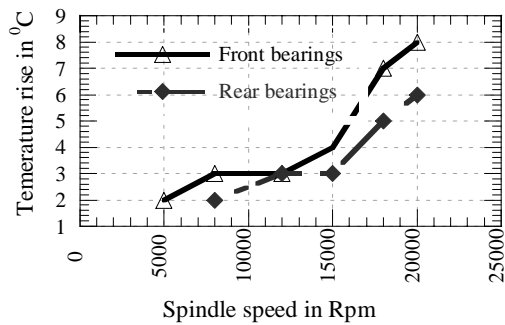

Fig.5 Temperature growth of ultra high speed spindle unit built with oil-air system

The temperature at the front and rear side of the bearing found to increase with spindle speed. Such trend shown in Fig. 5 follows a second order polynomial equation which is a measure of internal energy. The decreased energy rise is due to effectiveness of the oil-ir system. However the level of lubrication is less

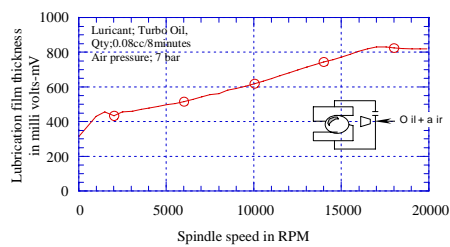

Fig.6 Lubrication film

significant at higher spindle speed. Study of the film thickness using capacitive method, which is shown in Fig. 6 confirms the presence of lubrication film around the rolling element at all speeds.

### 6.2 Radial error

The spindle error at the circumference of 200mm diameter dummy wheel is found to be within 8-10  $\mu$ m Geometrical errors are set to introduce additional frictional torque. The least radial error at the wheel periphery doubly confirms the negligible geometric error and the high precision in manufacturing and assembly of the developed unit.

### 6.3 Spindle power

Most of the high speed spindle consume 30% of total power for idle running [2]. In the built spindle the oil-air mist system performs efficiently introduces lubrication film and keeps the idle power within 10%.

### 6.4 Heat management

The computed and the measured result of the total heat generation, heat transfer and internal energy rise are plotted in Fig. 7. These values tend to increase with spindle speed. Fig 8 shows the computed result of each heat transfer component and Fig. 9 shows the behavior of convection coefficient with spindle speed . As the spindle speed rises the relative velocity between the outer race and inner race of the bearing changes and increases the ball spin velocity. This component rises the convection co-efficient and thus the spindle rolling element cooling is ensured.

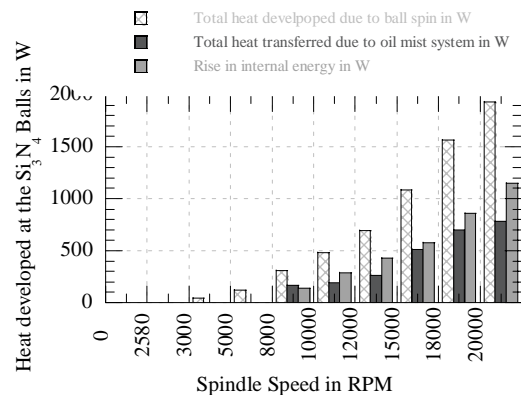

Fig. 7 Heat energy input and spreading arrangement in the UHSG spindle

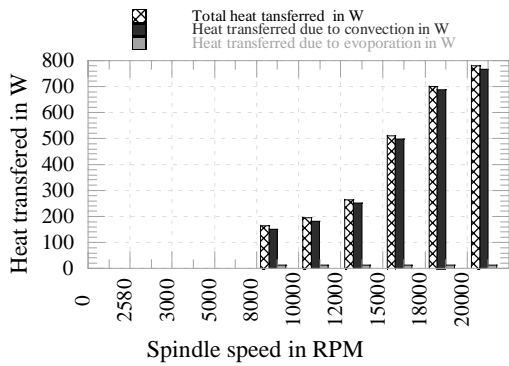

Fig. 8 Heat transfer components and its share with spindle speed

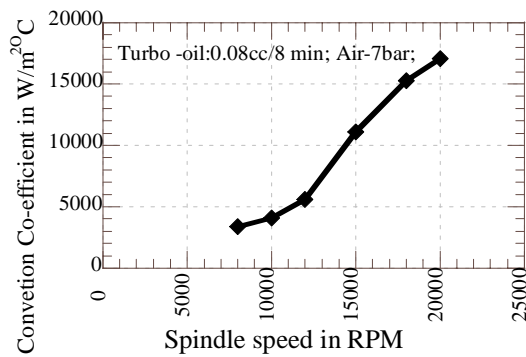

Fig.9. Convection heat transfer behavior with speed

## 7. Conclusions

Oil-air mist lubrication system maintains a thin film at all spindle speeds within the experimental range. The frictional heat at the rolling element increases with spindle speed and convection is the major component of heat transfer and found to be effective with spindle speed. Also higher DN factor such as  $1.4 \times 10^6$  was achieved with this method.

## 8. References

1. Weck.M & Koch.A, Spindle bearing systems for high speed applications in machine tools, *Annals of the CIRP*, Vol. 42/1/1993, 445-448
2. Webster.J.A, Design of a 250m/s CBN grinding machine, *SME*, 4<sup>th</sup> international Grinding Conference, 1991, MR90-551

3. Ando Shigenori, Masato Ota, Tadashi Kawashima, Spindle device having bearings lubricated with oil jet, *United States Patent*, 4,006,944, 1977
4. Tojiro Aoyama, Ichiro Inasaki, Satoshi Tsutsui & Tetsu Shimizu, Development of oil-air lubrication system with a piezoelectric nozzle for machine tool spindles, *JSME International Journal*, 1989, Series III, Vol.32, No.2, 259-263
5. Tomizawa.H & Fischer T.E, Friction and wear of silicon nitride at 150°C to 800 °C, *ASME Tribology conference*, 1985, 165-172
6. Al-Shareef, K.J.H & Brandon.J.A., On the effect of variations in the design parameters on the dynamic performance of machine tool spindle bearing systems, *International journal of machine tools manufacture*, 1990, Vol.30, 431-445
7. Zhao.Z & Poulidakos.D, Heat transfer and droplet on a substrate-1 Modeling, *International Journal of Heat Mass transfer*, 1996, Vol.39, No.13, 2771-2789
8. Hayashi Yujiro, Akira Takimoto & Osamu Matsuda, High performance of mist cooled heat exchanger, *Heat Transfer Science & Technology*, 1988, 617-622
9. Jin Kyung Choi & Dai Gil Lee, Manufacture of a carbon fibre-epoxy composite spindle-bearing system for a machine tool, *Composite structures*, 1997, Vol.37, 241-251
10. Zheng Chen, Jacques C.Cuneo, John J. Mecholsky Jr & Shoufeng Hu, Damage processes in  $Si_3N_4$  bearing material under contact loading, *Wear*, 1996, Vol. 198, 197-207
11. Katsuo Syoji, Tsunemoto Kuriyagawa, Yutaka Inada, Kunihiko Unno, Akinori Yui, Hideo Oushita & Kiyoshi Narita, Development of ultra high speed surface grinding machine, *JSPE*, 1997, Vol. 63, No.4, 560-564
12. Stolarski.T.A, *Tribology in machine design*, Heinemann newnes publisher, Oxford, 1990, 258-259
13. Inada, *Studies in ultra high speed grinding*, Phd thesis, Tohoku university, Japan, Engineering research center, July 1996.

